

Ceilings

Architectural Forms HCC

Description

Decoustics HCC Composite Construction is a very lightweight 2-1/4" (57 mm) thick panel that lends itself to an artistic, free form style of design. Panels are typically suspended in ceiling areas and can be supported using only one hanger if desired which enables the panel to be fixed to virtually any angle. Finishes applied are to both sides of the panel and edges. A high absorption core HCCF is available for increased sound control. Panels are hanger mounted using a Decoustics supplied yoke assembly for single point suspension or D-ring/eyebolts for multi-point suspension.

Panels

All Decoustics panels are custom fabricated and offered in a variety of types, sizes, geometric shapes, thicknesses and finishes.

Design Considerations

Panels employing single suspension are easily adjustable allowing different visual configurations and acoustical results. Panels employing multi-point suspension are typically hung in one position, however, they may be de-installed and re-hung at a different angle by changing the length of the suspension device e.g. hanger cable/chain, or rod.

Dimensional tolerance of these panels is approx. $\pm 1/8"$ (3 mm).

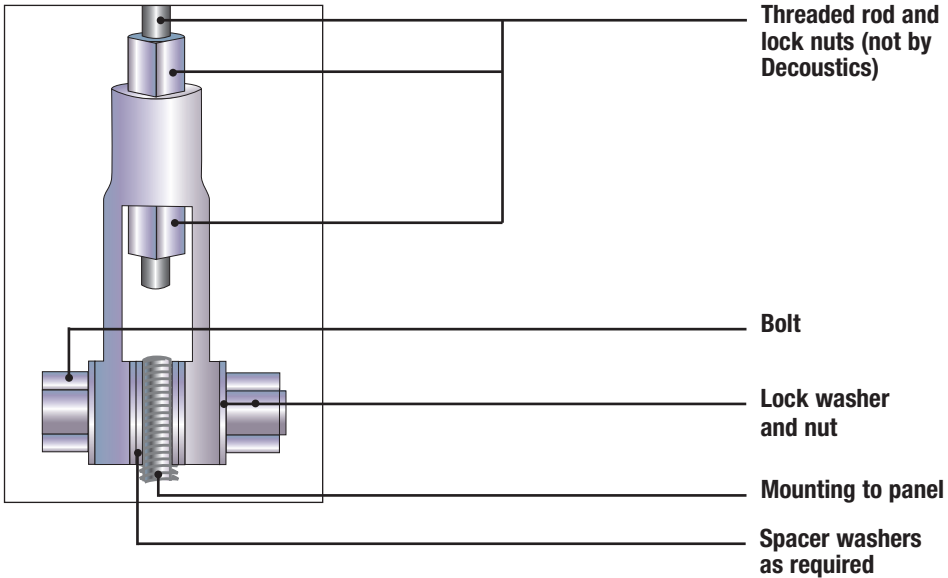
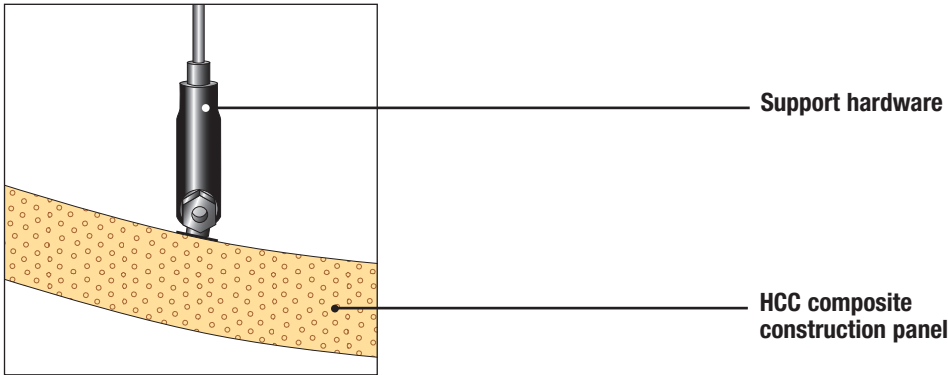
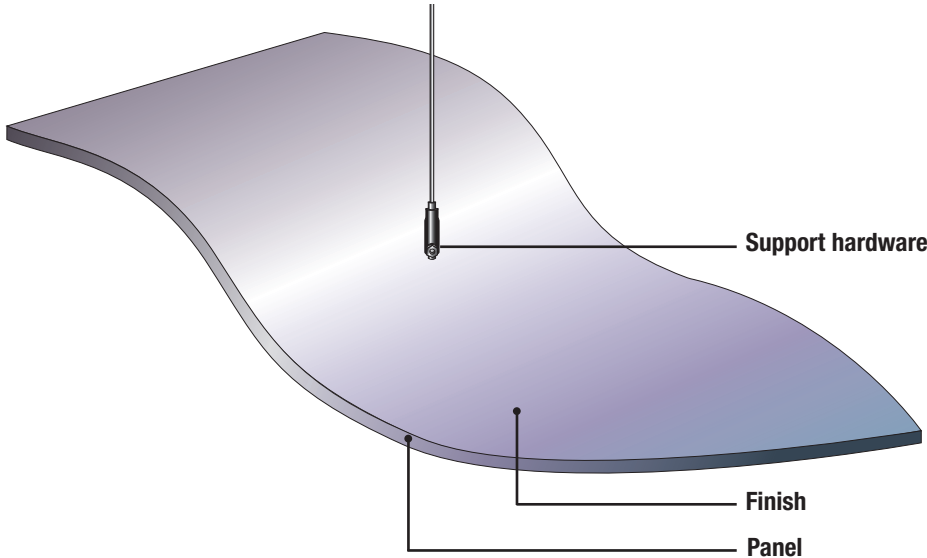

Ceilings

Architectural Forms HCC

Maintenance

Refer to appropriate Decoustics "Cleaning & Maintenance Instructions" for any specific finish.

Related Data

Decoustics 3-Part Guide Specifications.

Standards, Tests and Approvals

Surface Burning Characteristics (ASTM E-84):

All panel components have a Flame Spread rating of less than 25.

Note: Building code requirements may necessitate composite panel testing based on specified finish.

A panel comprised of "Class A" (Flame Spread of 25 or less) components does not necessarily produce a composite panel meeting the "Class A" requirement. Decoustics has a considerable number of composite panel tests on file.

Mounting Methods

Mechanically mount only using installer supplied threaded rod (single point suspension) or hanger cable/chain (multi-point suspension).

Only handle panels wearing clean, lightweight, white gloves during installation.

Follow manufacturer's printed instructions for installation. Field cutting of panels is not recommended

FINISH	EDGE OPTIONS	SIZES	CONSTRUCTION	THICKNESS	NRC	WEIGHT	COLOR
<i>Claro or Metallo II</i>	Resin: square edge	Up to 48" x 96" (1220 mm x 2440 mm)	Panel consists of reinforced lightweight internal structure 6 to 7 pcf (96 to 112 kg/m ³) core with a 1/8" (3 mm) 16 to 20 pcf (256 to 320 kg/m ³) high density integral facer with a non-bridging acoustically transparent coating.	2-1/4"	0.90	1.1 psf (5.37 kg/m ²) 1.4 psf (6.83 kg/m ²) with acoustically absorptive filler	Standard White CSW-100 Light Reflectance 90% or Custom colors

Note: The information provided in this Data Sheet is accurate to the best of our knowledge at the time of printing. However, we reserve the right to make changes when necessary without further notification. Suggested applications may need to be modified to conform with local building codes and conditions. We cannot accept responsibility for products that are not used, or installed, to our specifications. Please refer to our website for most current data.

Note: Only handle panels wearing clean, lightweight, white gloves during installation. Follow manufacturer's printed instructions for installation as well as field cutting of panels.